

A Comparative Analysis of M-GEAR and MODLEACH Energy Efficient WSN Protocols

Neeraj Dewli^{#1}, Mrs. Rashmi Saini^{*2}

[#]M Tech Scholar

Computer Science and Engineering Department, GBPEC
Pauri Garhwal, Uttarakhand, India

^{*}Assistant Professor

Computer Science and Engineering Department, GBPEC
Pauri Garhwal, Uttarakhand, India

Abstract— Wireless Sensor Networks (WSNs), have served mankind to monitor the environment of the places which are insurmountable. The sensor nodes have limited energy to sense and send the data. The consumption of energy should be efficient so that network lifetime as well as the throughput is improved. Some of the routing protocols have been devised to route the data sensed by the sensors in the WSN are aimed to be energy efficient. Clustering based Energy efficient Routing protocols mainly dwell on increasing the lifetime as well as performance of the network. LEACH based protocols can be modified to give a network more lifetime and improved performance. In this paper, we have analyzed and compared two WSN protocols, M-GEAR and MODLEACH, on the grounds of network lifetime and performance of the network.

Keywords— M-GEAR, MODLEACH, LEACH, WSN, Cluster Head (CH).

I. INTRODUCTION

Improvements in algorithms open many doors to new developments in current technology. Wireless Sensor Networks (WSN) are providing services to mankind to gather the information in critical environmental conditions. WSNs can be used to collect information from war field to monitor household devices or robots. The efficient use of resources always helps to improve the performance of the network. The performance of the WSN is improved by increasing the lifetime of the WSN [3]. Low power consuming routing protocol maintains the energy level of the network higher to improve lifetime.

The sensor nodes used in WSNs have a limited power source. The goal of a sensor node is to sense the environment and send the sensed data for further processing. For every WSN there exists a Base Station (BS) which receives and collects the data sent by the sensor nodes. The energy which is spent on sending a k bit data is much more than receiving k bit data [3]. Energy to send one bit of data depends upon the distance between the sender node and the receiver node. If sensor nodes were to send data directly to the BS the nodes which are farther have to spend more energy to send k bit data to BS [3]. So the sensor nodes which are located far from the BS would die earlier than the sensor nodes which are located nearer to BS.

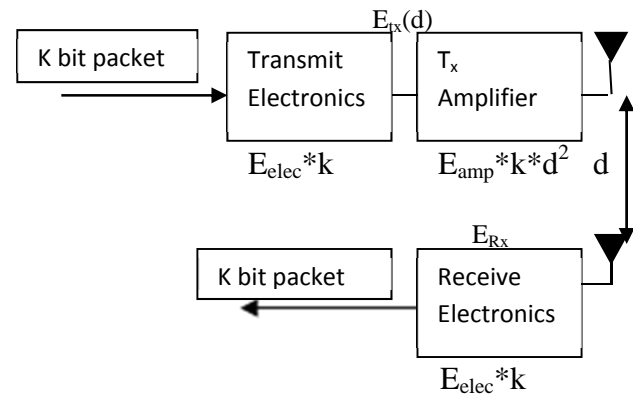

Fig.1 Energy Spend In Radio Transmission [3]

To prevent this disparity and improve the lifetime of WSN LEACH was proposed by Wendi Rabiner Heinzelman et al in 2000 [3]. LEACH is a clustering based routing protocol for WSNs. The sensor nodes are made to form several clusters in the sensing region. LEACH is a self-organizing, adaptive clustering protocol that uses randomization to distribute the energy load evenly among the sensors in the network [3]. A cluster head (CH) is chosen at each round in a cluster. All sensor nodes in a cluster transmit data directly to the local CH. Then CH gathers all data from sensor nodes in the cluster and sends the data to BS. After each round a new cluster head is elected.

In this paper two routing protocols M-gear and MODLEACH have been analyzed and compared. M-gear [1] was proposed by Q. Nadeem et al is LEACH based routing protocol for WSNs. MODLEACH [2] was proposed by D. Mahmood et al is also a LEACH based protocol for WSNs.

II. RELATED WORK

There are several routing protocols proposed that can be analyzed in the context of wireless sensor networks. We study and compare two such protocols, namely M-gear and Mod-Leach using our sensor network and radio models. The sensor nodes which are used in WSNs have limited computing ability and transmitting/receiving power. This power must be used in such a manner so that the sensor nodes live longer.

Initially Direct Transmission to BS was discussed [3]. Node directly sends the sensed data to BS. This approach is secure but leads to higher power consumption. Nodes which are located farther die earlier than the nodes which are located nearer to the BS. To overcome this problem minimum transmission energy (MTE) was developed. In MTE the data is transmitted using multiple hops. This again rose a similar problem, the only difference is that now the nodes which are nearer to BS began to die earlier. Estrin et. al [4] worked on an hierarchical clustering mechanism dealing with a symmetric communication for power saving in sensor nodes. According to this mechanism, all participating nodes of network are distributed in 2-hop cluster. Though this protocol is not much energy efficient for wireless sensor nodes however, it gives way to hierarchical clustering algorithms. Clustering for energy conservation is proven as efficient mechanism for wireless sensor networks [5,6].

When a sensor network is deployed, nodes establish clusters and nominate one node from each cluster as a cluster head. These cluster head nodes are responsible for receiving data from other nodes of cluster, do data aggregation/fusion of received data and transmit it to base station. The data transmission from sensor nodes in a cluster to cluster head of that cluster is done using TDMA. Each Node waits for its Time slot to send the data to cluster head. In this way, bandwidth consumption and life time of network is optimized [7].

Considering cluster based algorithms, today several protocols are developed, each having several attributes and enhancements mainly in cluster head selection algorithms. Though one thing is common, all protocols focus on energy conservation and data aggregation. Main procedure of electing a cluster head was given by LEACH and that is further enhanced by SEP and DEEC.

This article dwells on comparative study of two such LEACH based routing protocols for efficient energy consumption.

III. MODLEACH

LEACH opens scope for many routing protocols for WSNs. The procedures in LEACH deal with homogeneous network. According to LEACH new cluster head is elected for every round. This leads to new cluster formation for each round. New cluster formation for each round wastes a significant amount of limited energy. If current cluster head has more energy than some of the clusters in the cluster, then in the next round a node with less energy can be elected as new cluster head. So residual energy of current cluster head must be taken into consideration before the election of new cluster head. Hence new cluster head replacement algorithm was introduced by D. Mahmood et al.

The energy required to transmit data from a node to cluster head is directly proportional to the square of the distance between node and cluster head. Hence nodes residing near the cluster head must use low amplification of the signal than that of the nodes which are located far from cluster head. So D. Mahmood et al proposed a dual transmitting power levels also.

A. Efficient Cluster Head Replacement Algorithm

It is a threshold in cluster head formation for very next round. If existing cluster has not spent much energy during its tenure and has more energy than required threshold, it will remain cluster head for the next round as well. This is how, energy wasted in routing packets for new cluster head and cluster formation can be saved. If cluster head has less energy than required threshold, it will be replaced according to LEACH algorithm [2].

B. Dual Amplification Levels For Data Transmission

There are three modes of transmission in a cluster based WSN.

1. Intra Cluster Transmission
2. Inter Cluster Transmission
3. Cluster Head To Base Station Transmission

Node senses the data and sends it to cluster head directly this transmission is intra cluster transmission. Cluster head aggregates the data received from nodes and transmits the data to base station this is Cluster head to Base station transmission. The transmission among Cluster Heads is termed as Inter Cluster Head Transmission. The minimum energy required for all three kinds of transmissions cannot be the same.

So when a node is elected as the cluster head it uses high power to amplify the signal. And in the next round when other node is elected as the cluster head it uses small power to amplify the signal.

IV. M-GEAR

In most cluster based protocols Cluster Head is selected on the base of probability. Generally Cluster Heads are distributed uniformly throughout the field of sensor. So it is possible that the Cluster Heads selected can be concentrated in one region of the network.

Hence, some of the nodes would not get any Cluster Heads in their environment. Similarly some protocols used unequal clustering and try to use recourse proficiently [1].

Sensor nodes have sensed data for BS to process. Therefore, an automatic method of combining or aggregating the data into a small set of momentous information is required [9] [10]. Data fusion is the process of data aggregation. To improve network lifetime and throughput, we deploy a special kind of node, called gateway node, at the center of the sensor network field. The gateway node collects and aggregates data from Cluster Heads and nodes near gateway, and sends to BS. The results show that network lifetime and energy consumption improved. We add rechargeable gateway node because it is on ground fact that the recharging of gateway node is much cheaper than the price of sensor node [1].

The implementation of M-GEAR protocol is done in following phases [1]:

A. Initial Phase

The sensor nodes are distributed in the sensor field randomly. The BS sends a request packet to all nodes to enquire their location. The sensor nodes respond with their location to the BS. BS keeps this information about all nodes.

B. Setup Phase

The region is divided into four logical regions. First one is the one where the sensor nodes are nearer to the BS. The nodes in first region direct transmit the sensed data to the BS. Second region is the one where nodes are near the gateway node. The nodes in second region directly send data to the gateway node. Now the rest of the region is divided into two clusters, where Cluster Heads are selected for each round. Cluster heads in the clustered region receive the data from the nodes in the cluster and aggregate and send the data to the gateway node.

C. CH Selection

Initially BS divides the network into regions. CHs are elected in each region separately. Let r represent the number of rounds to be a CH for the node S_i . Each node elect itself as a CH once every $r = 1/p$ rounds. At the start of first round all nodes in both regions has equal energy level and has equal chance to become CH. After that CH is selected on the basis of the remaining energy of sensor node and with a probability p alike LEACH. In each round, it is required to have $n \times p$ CHs. A node can become CH only once in an epoch and the nodes not elected as CH in the current round fill right to the set C . The probability of a node to (belongs to set C) elect as CH increases in each round. It is required to uphold balanced number of CHs. At the start of each round, a node S_i belongs to set C autonomously choose a random number between 0 to 1. If the generated random number for node S_i is less than a predefined threshold $T(s)$ value then the node becomes CH in the current round.

The threshold value can be found as:

$$T(S) = \begin{cases} \frac{p}{1 - p \times (r \bmod (1/p))} & \text{if } s \in C \\ 0 & \text{otherwise} \end{cases}$$

Where P = the desired percentage of CHs and r = the current round, C = set of nodes not elected as CH in current round.

After electing CHs in each region, CHs inform their roletto neighbor nodes. CHs broadcast a control packet using a CSMA MAC protocol. Upon received control packet from CH, each node transmits acknowledge packet. Node who finds nearest CH, becomes member of that CH.

D. Scheduling

After Cluster Head is elected for the current round in the cluster, the Cluster Head creates TDMA slots for the sensor nodes in the cluster. Each sensor node in the cluster waits for its TDMA time slot to send the data to the Cluster Head.

E. Steady-State Phase

In this fashion the Cluster Heads are elected for each round and sensor nodes send their data to corresponding Cluster Heads in TDMA time slot allotted to them. Cluster Heads aggregate and send the data to the gateway node. The gateway node collects the data from the Cluster Heads and the nodes near the gateway node then sends the aggregated data to the Base Station.

V. EXPERIMENTAL RESULTS AND COMPARISON

A. Simulation

To assess the parameters to make comparisons between the protocols M-GEAR and MODLEACH MATLAB simulation is used. A 100 X 100 sensor field is used to disperse the nodes. For homogeneity Base Station is placed far away from sensing field at (50, 120) for both protocols. The sensor nodes are randomly dispersed in 100 X 100 sensing field. Same distribution of sensor node is supplied for both protocols.

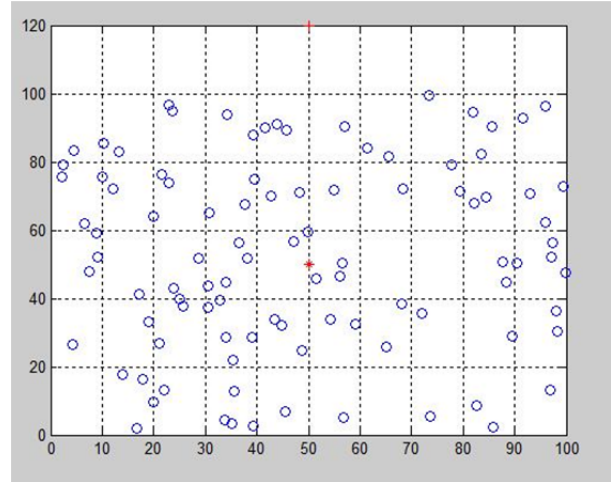

Fig. 2 Randomized Nodes Placement

For M-GEAR gateway node is placed at (50, 50) coordinates. First region, where nodes directly transmit data to Base Station, constitute all the nodes which have Y coordinate greater than 80. Second region, where nodes send data directly to gateway node, are located at the center. And the remaining region is divided into two clusters where Cluster Head are elected for each round.

TABLE I NETWORK PARAMETERS

S. No.	Network Parameters	Value
1.	Network Size	100x100
2.	Initial Energy of Node	0.5 J
3.	Packet Size	4000 bits
4.	E_{elec}	5 nJ/bit
5.	Amplification Energy in M-Gear	$E_{fs1} = 10 \text{ pJ/bit/m}^2$
6.	Amplification Energy in MODLEACH (Cluster to BS) for $d > d_0$	$E_{fs1} = 10 \text{ pJ/bit/m}^2$
7.	Amplification Energy in MODLEACH (Cluster to BS) for $d < d_0$	$E_{mp1} = 0.0013 \text{ pJ/bit/m}^2$
8.	Amplification Energy in MODLEACH (Intra Cluster Comm.) for $d > d_1$	$E_{fs2} = E_{fs1} / 10$
9.	Amplification Energy in MODLEACH (Intra Cluster Comm.) for $d < d_1$	$E_{mp2} = E_{mp1} / 10$

B. Performance Parameters

1) Network lifetime: It is the time interval from the start of the network operation till the last node die.

2) Throughput: To evaluate the performance of throughput, the numbers of packets received by BS are compared with the number of packets sent by the nodes in each round.

C. Simulation Result And Analysis

1) Network Lifetime: After running the simulation several times we always find out that M-GEAR outperforms LEACH and MODLEACH both. By performing simulation in MATLAB following data was produced.

TABLE II
NETWORK LIFETIME MEASURED BY THE MAXIMUM NUMBER OF ROUNDS TILL THE LAST NODE WAS ALIVE

No. of Run	M-GEAR	MODLEACH	LEACH
1.	2498	2312	1577
2.	2492	2197	1687
3.	2500	2071	1510
4.	2496	2316	1660
5.	2501	2205	1464
6.	2468	2172	1669

By analyzing the Fig. 3 we can see that nodes in the case of M-GEAR protocol start to die earlier but total network lasts longer than MODLEACH.

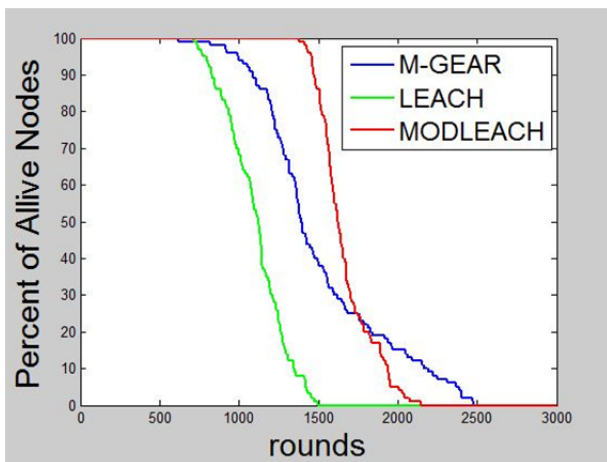

Fig. 3 Network Lifetime

2) Throughput: By analyzing Fig. 4 we see that the throughput of M-GEAR is greater than that of MODLEACH. This is because M-GEAR maintains residual energy of sensor nodes to last long using the gateway node.

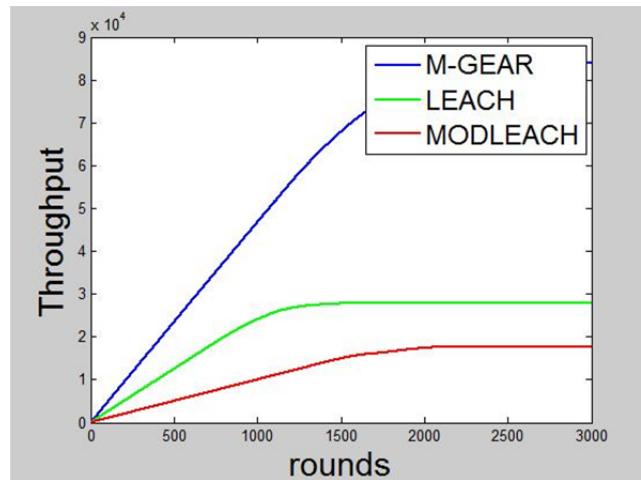

Fig. 4 Network Throughput

VI. CONCLUSION

We have analyzed and compared the performances of two routing protocols M-GEAR and MODLEACH on the basis of network lifetime and throughput. Although, the performance of MODLEACH is improved as compared to LEACH but the introduction of the gateway node has improved the performance of the network. According to the analysis based on MATLAB simulation we clearly see that gateway node which is deployed in the case of M-GEAR improves the network lifetime as well as the throughput of the network. Hence we conclude that at the expense of the gateway node one can easily achieve higher performance of the network.

REFERENCES

- [1] Q. Nadeem, M. B. Rasheed, N. Javaid, Z. A. Khan, Y. Maqsood and A. Din, *M-GEAR: Gateway-Based Energy-Aware Multi-Hop Routing Protocol for WSNs*, Eighth International Conference on Broadband and Wireless Communication and Application, pp. 164-169, 2013.
- [2] D. Mahmood, N. Javaid, S. Mahmood, S. Qureshi, A. M. Memon and T. Zaman, *MODLEACH: A Variant of LEACH for WSNs*, Eighth International Conference on Broadband and Wireless Communication and Applications, pp. 158-163, 2013.
- [3] W. Heinzelman, A. Chandrakasan, and H. Balakrishnan. *Energy-Efficient Communication Protocols for Wireless Microsensor Networks*, Hawaiian International Conference on Systems Science, January 2000.
- [4] D. Estrin, R. Govindan, J. Heidemann, and S. Kumar. *Next Century Challenges: Scalable Coordination in Wireless Networks*, 5th Annual ACM/IEEE International Conference on Mobile Computing and Networking (MOBICOM), pp. 263-270, 1999.
- [5] C. Y. Chong and S. P. Kumar, *Sensor Networks: Evolution, Opportunities and Challenges*, IEEE, 91, No. 8, pp. 1247-1256, Aug 2003.
- [6] M. Younis, P. Munshi, G. Gupta and S. M. Elsharkawy, *On Efficient Clustering of Wireless Sensor Networks*, Second IEEE Workshop on Dependability and Security in Sensor Networks and Systems, pp.78-91, 2006.
- [7] L.M.C. Arboleda and N. Nasser, *Comparison of Clustering Algorithms and Protocols for Wireless Sensor Networks*, Canadian Conference on Electrical and Computer engineering, pp. 1787-1792, May 2006.
- [8] McMullen, A. Sonya, *Mathematical Techniques in Multisensor Data Fusion*, 2nd Edition." (2004).
- [9] Klein, A. Lawrence, *Sensor and data fusion concepts and applications*, Society of Photo-Optical Instrumentation Engineers (SPIE), 1993.